

# Pressure Control Valves

## Back Pressure Regulators UV 1.5

Valve in Intermediate Flange Design



### Technical Data

Connection DN	25, 50
Nominal Pressure PN	40
Inlet Pressure	1 - 40 bar
K <sub>vs</sub> -Value	10.5 and 19 m <sup>3</sup> /h
Temperature	-20 up to 80 °C
Medium	liquids

### Description

Self-acting back pressure regulators are simple control valves offering accurate control while being easy to install and maintain. They control the pressure upstream of the valve without requiring pneumatic or electrical control elements.

The back pressure regulator UV 1.5 is a pilot-operated control valve with proportional control mode consisting of main valve and pilot valve. It is completely made of stainless steel with excellent corrosion resistance. Its intermediate flange design with limited size makes the valve extremely lightweight and compact. The valve cone has a metallic seal.

The sturdy valve design and the metallic valve seal do not require any particular filtration of the operating fluid. Thanks to its medium-wetted movable components, the valve is largely maintenance-free. In addition, it can be installed in any desired mounting position.

#### Special notes:

The seal on the outlet side must not cover the outflow bore of the pilot valve (observe measurement!)

These valves are no shut-off elements ensuring a tight closing of the valve. In accordance with DIN EN 60534-4 and/or ANSI FCI 70-2 they may feature a leakage rate in closed position in compliance with the leakage classes II.

### Standard

- » All stainless steel construction
- » FKM elastomers (O-rings)
- » 2014/68/EU Art. 4 Par. 3

### Typical Applications

Maintaining the required lub oil pressure for the use of main and auxiliary oil pumps, for ex. compressors, gears, slide bearings, drive shafts etc., Pressure control of fuels / fuel oils in power plants. Control of minimum quantities for centrifugal pumps with oil / oily fluids. Lub oil systems, for ex. for steam and gas turbines, large diesel engines for ship propulsion and cogeneration units (CHP).

Operating instructions, know how and safety instructions must be observed. The pressure has always been indicated as overpressure. We reserve the right to alter technical specifications without notice.



#### K<sub>vs</sub>-Values [m<sup>3</sup>/h]

nominal diameter	DN 25	DN 50
m <sup>3</sup> /h	10,5	19

#### Setting Ranges [bar], Nominal Pressure

Setting Range	1 - 20	12 - 40
Nominal Pressure	PN 40	PN 40

# Pressure Control Valves

## Back Pressure Regulators UV 1.5

Valve in Intermediate Flange Design



### Materials

Body	stainless steel 1.4404
Inner Parts	stainless steel 1.4404 / 1.4462 / 1.4301
O-ring	FKM
Spring	stainless steel 1.4310
Screws	stainless steel A4-70

### Dimensions [mm]

size	nominal diameter	
	DN 25	DN 50
A	40	50
B	75	85
øD	70	100
øE	22	35
øF	49	69

### Flanges

nominal diameter DN 25	nominal diameter DN 50
EN 1092-1 PN 40 DN 25, DN 32, DN 40   ASME B16.5 Class 300 NPS 1', NPS 1 - 1/2'	EN 1092-1 PN 40 DN 50, DN 65   ASME B16.5 Class 300 NPS 2', NPS 2 - 1/2'

### Weights [kg]

nominal diameter	DN 25	DN 50
kg	1.0	2.4

### Dimensional Drawing

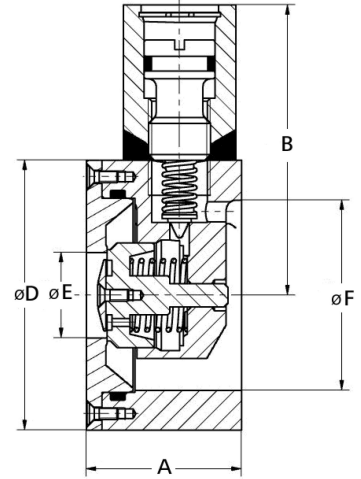

### Flow Chart

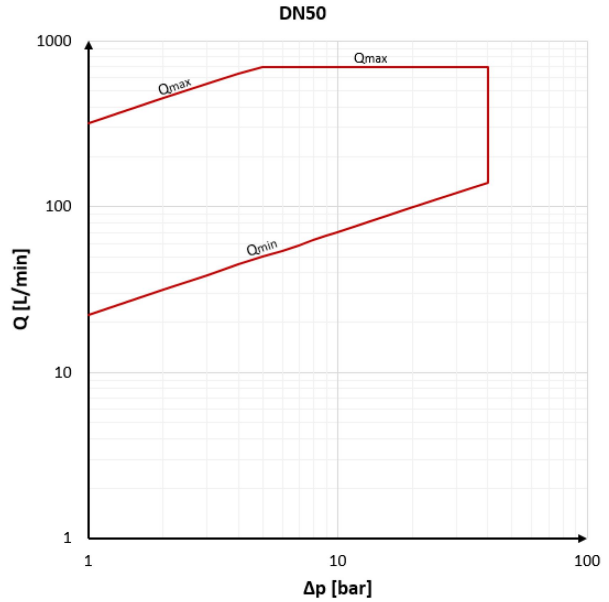
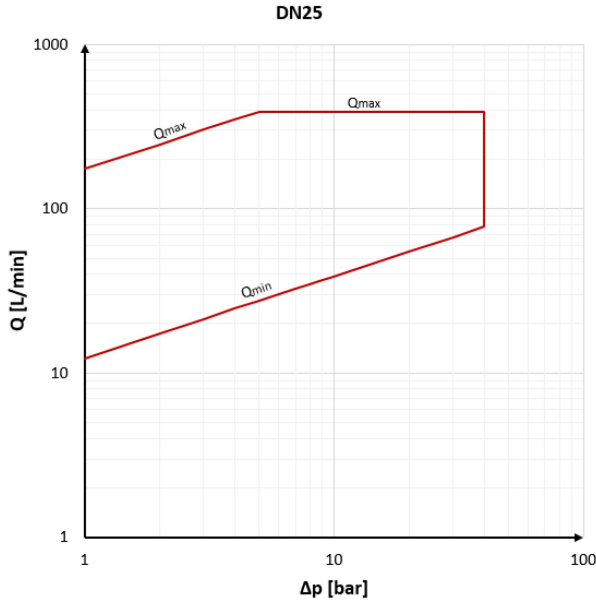

$$Q \text{ [m}^3\text{/h]} = Q \text{ [L/min]} / 1000 \times 60$$

We reserve the right to alter technical specifications without notice.

# Pressure Control Valves

## Back Pressure Regulators UV 1.5

Valve in Intermediate Flange Design



### Control Curve

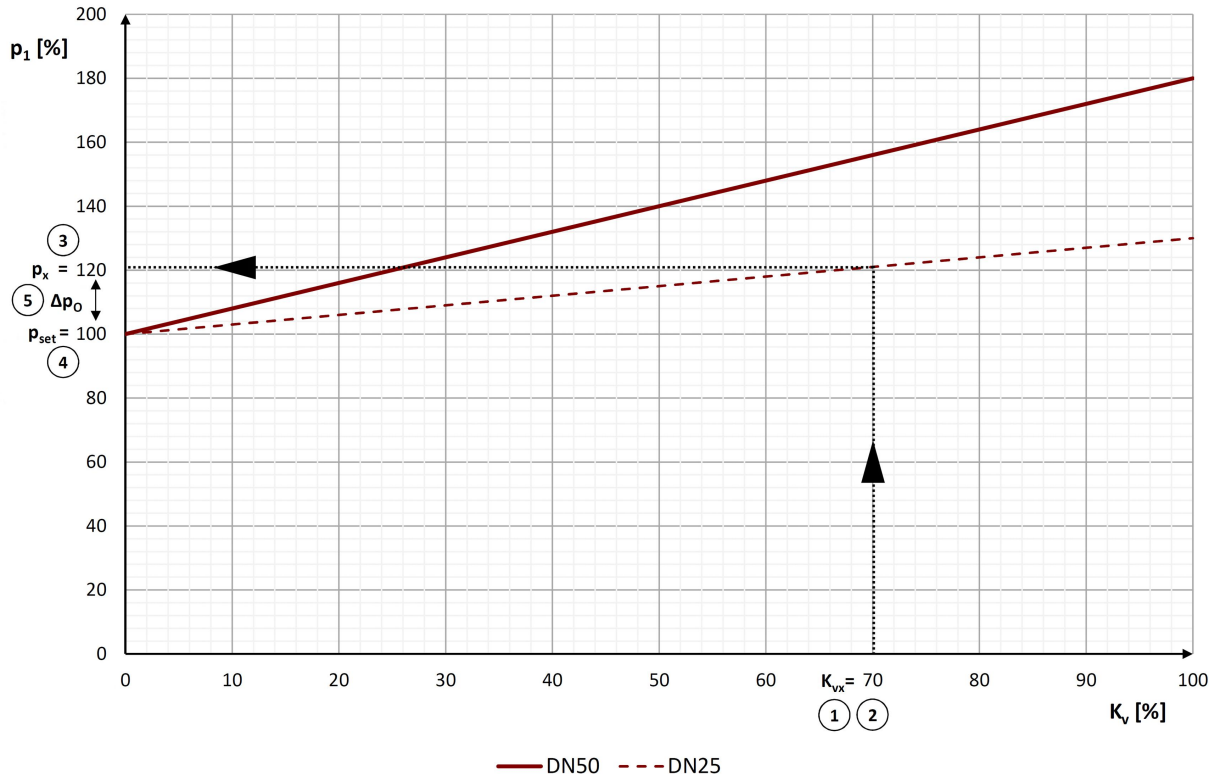

$p_1$  : Inlet Pressure                       $K_{vx}$  : Flow coefficient at operating point                       $p_{set}$  : set pressure of the valve  
 $p_2$  : Outlet Pressure                       $K_{vs}$  : max. flow coefficient of the valve                       $\Delta p_O$  : Opening pressure difference  
 $Q$  : Operating volumetric flow                       $p_x$  : Upstream pressure at operating point

### Example

Determination of the opening pressure difference  $\Delta p_O$  for UV1.5 DN25

hydraulic oil ISO VG 46,  $T = 60 \text{ }^\circ\text{C}$ ,  $Q = 23.6 \text{ m}^3/\text{h}$ ,  $p_1 = 10 \text{ barg}$ ,  $p_2 = 0 \text{ barg}$ ,  $K_{vs} = 10.5 \text{ m}^3/\text{h} = 100\%$

1.  $K_v = 7.3 \text{ m}^3/\text{h}$
2.  $K_{vx} = K_v / K_{vs} \times 100 \% = 70 \%$
3.  $p_x = p_1 = 10 \text{ barg} = 120 \%$
4.  $p_{set} = p_1 / p_x \times 100 \% = 10 \text{ barg} / 120 \% \times 100 \% = 8.3 \text{ barg}$
5.  $\Delta p_O = p_x - p_{set} = 10 \text{ barg} - 8.3 \text{ barg} = 1.7 \text{ bar} = 20 \%$

The expected pressure drop from the operating point until the valve closes is 1.7 bar.

We reserve the right to alter technical specifications without notice.

# Pressure Control Valves

## Back Pressure Regulators UV 1.5



Valve in Intermediate Flange Design

### Function

To control the upstream pressure, the required set pressure at the valve is set at the adjusting screw (11). Use a common slot screwdriver for this purpose. Turning to the right increases the set pressure, turning to the left reduces the set pressure.

The piston chamber is fed via the gap at the baffle plate (6) and the control bore in the piston (5). In closed condition, the closing forces at the piston (5) prevail and keep the valve closed.

Once the pressure in the piston chamber goes beyond the set pressure, the cone (9) is lifted off the seat of the pilot valve against the pressure spring (10). The outflow to the outlet side causes a pressure drop in the piston chamber which lifts the piston (5) off the seat (4) and opens the back pressure regulator. The resulting balance of opening and closing forces keeps the piston (5) in position.

We reserve the right to alter technical specifications without notice.

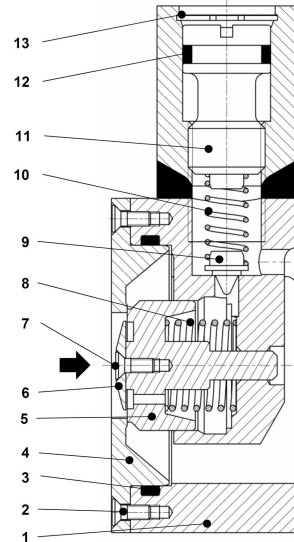

Main Valve	Pilot Valve
1 body	9 cone
2 countersunk head screw	10 pressure spring
3 O-ring	11 set screw
4 seat	12 O-ring
5 piston	13 circlip
6 baffle plate	
7 countersunk head screw	
8 pressure spring	