

Pressure Control Valves

Pressure Reducing Valves DM 462V

Valve for Hygiene Applications / Ultrapure Media



Technical Data

Connection DN	25
Nominal Pressure PN	2.5 - 16
Inlet Pressure	8 bar
Outlet Pressure	0.8 - 5 bar
K _{vs} -Value	4 m ³ /h
Temperature	180 °C
Medium	liquids, gases and steam

Description

Self-acting pressure reducers are simple control valves offering accurate control while being easy to install and maintain. They control the pressure downstream of the valve without requiring pneumatic or electrical control elements.

The pressure reducing valve DM 462V is a double-seat diaphragm-controlled and spring-loaded proportional control valve which is predominantly used for hygiene applications in the foodstuffs and pharmaceutical industry. Owing to the PTFE protecting foil the diaphragm is physiologically harmless and can be exposed to steam at a temperature of up to 180°C. The valve cone is fitted with a soft seal.

The valve is made of stainless steel featuring excellent resistance to corrosion. It has cavity-free internals and is suitable for CIP and SIP. The angled design allows for complete draining. The precise cone spindle guide is arranged outside the throughflow space, thus there is no abrasion in the space through which the medium flows. The design was carried out in accordance with ASME BPE. Clamp connections in accordance with DIN 32676, DIN 11866 line A are standard.

The spring cap with spring module and adjusting screw, body bottom (outlet), diaphragm and internals are connected to the body by means of two profile clamps.

Thus replacement of the diaphragm or of the entire spring module for another regulating range can be easily done without using special tools. This also applies for maintenance work. Setting the regulating pressure does not change the valve's overall height (non rising adjusting screw).

The outlet pressure to be controlled is balanced across the control unit by the force of the valve spring (set pressure). As the outlet pressure rises above the pressure set using the adjusting screw, the valve cone moves towards the seat and the volume of medium is reduced. As the outlet pressure drops, the valve control orifice increases; when the pipeline is depressurised, the valve is open. Rotating the adjusting screw clockwise increases the outlet pressure.

These valves are no shut-off elements ensuring a tight closing of the valve. In accordance with DIN EN 60534-4 and/or ANSI FCI 70-2 they may feature a leakage rate in closed position in compliance with the leakage classes V.

Standard

- » All stainless steel construction (medium wetted 1.4404/1.4435, 316L)
- » Clamping flanges acc. to DIN 32676
- » Non rising adjusting screw
- » Quick-release body clamp ring
- » Diaphragm protected by PTFE foil

Options

- » Straight-through design or three connecting pieces
- » Polished version for food, pharmaceutical and superclean applications (Ra ≤ 0.25/ ≤ 0.4/ ≤ 0.8 µm)
- » Electro-pneumatic activation
- » For toxic or hazardous media: sealed spring cap complete with leakage line connection (incl. sealed adjusting screw). Must be installed with a leakage line capable of draining leaking medium safely and without pressure
- » Various diaphragm and seal materials suitable for your medium
- » Special connections: Aseptic, ANSI or DIN flanges, welding spigots; other connections on request
- » Special versions on request

Operating instructions, know how and safety instructions must be observed. The pressure has always been indicated as overpressure. We reserve the right to alter technical specifications without notice.



K_{vs}-Values [m³/h]

nominal diameter DN

25

4

Pressure Ranges [bar] and Nominal Pressure PN

0.8 - 2.5

2 - 5

PN 16/6

PN 16/10

Pressure Control Valves

Pressure Reducing Valves DM 462V

Valve for Hygiene Applications / Ultrapure Media



Materials

Temperature	130 °C	180 °C
Body, Spring Cap, Internals	CrNiMo-steel	CrNiMo-steel
Valve Seal	EPDM	FEPM
Spring	CrNi-steel	CrNi-steel
Diaphragm	EPDM	FKM
Protection Foil for Diaphragm	PTFE	PTFE

Dimensions [mm] angle design

size	nominal diameter DN (clamps)
	25
AE*	85
C	205
D	107

Dimensions [mm] straight-through design

size	nominal diameter DN (clamps)
	25
A*	140
B	45
C	205
D	107

* Overall length tolerances in acc. with DIN EN 558

Weights [kg]

nominal diameter DN (clamps)
25
5

Customs Tariff Number

84811019

Special designs on request.

The pressure has always been indicated as overpressure.

Mankenberg reserves the right to alter or improve the designs or specifications of the products described herein without notice.

Dimensional Drawing

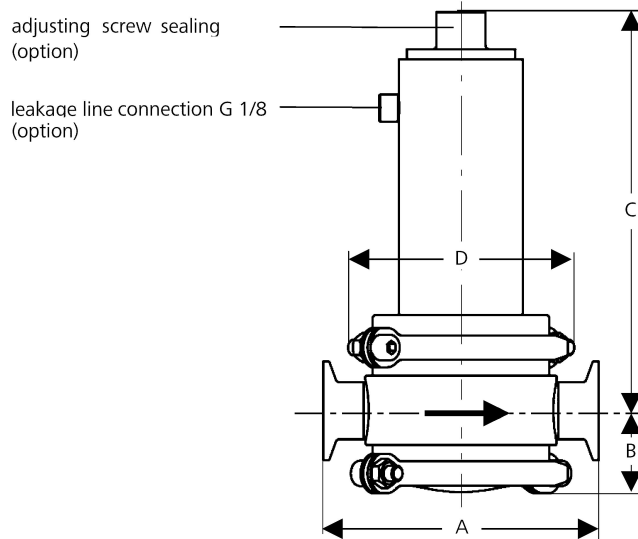
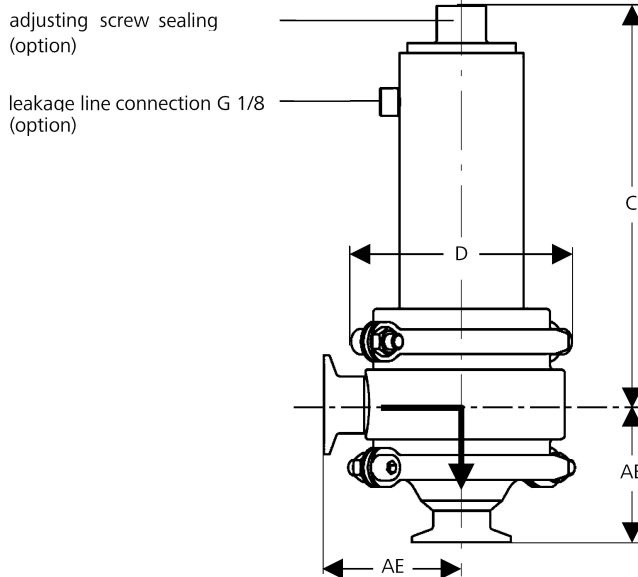

Recommended Installation

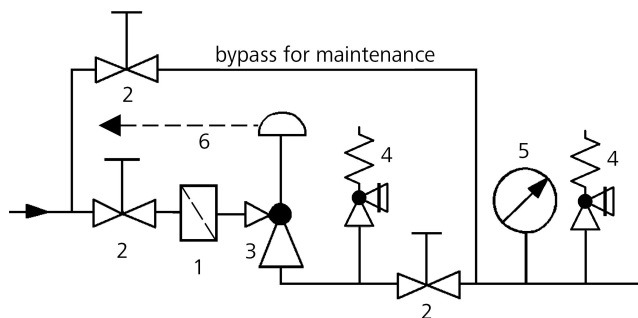

- 1 Strainer*
- 2 Shutoff valves
- 3 Overflow Valve*
- 4 Safety Valve*
- 5 Pressure Gauge
- 6 Leakage Line G 1/8 (option)

*Use MANKENBERG-Products